

Koelnmesse Pte Ltd
152 Beach Road
#25-05 Gateway East
Singapore 189721
Tel: +65 6500 6700
Fax: +65 6294 8403
l.how@koelnmesse.com.sg
www.thaifex-anuga.com



26 - 30 May 2020

Application for
MAIN EXHIBITOR

Deadline:
30 March 2020

1.10

1. Main Exhibitor

1.1 Address

Company Name:

Address:

City, Postal Code:

Country:

Website:

Contact person for the exhibition is:

Mr Ms

Position at the company:

Phone:

Fax:

Email:

1.2 We are a/an:

- Association/Institution/Government
 Importer
 Manufacturer
 Service Provider
 Trading Company
 Wholesaler/Distributor
 Others

1.3 We wish to exhibit in the following segment:

- Coffee & Tea Fruits & Vegetables
 Drinks Meat & Poultry
 Fine Food Rice
 Food Service Seafood
 Food Technology Sweets & Confectionery
 Frozen Food

1.4 We wish to exhibit in the following special zones*:

- THAIFEX Halal Market THAIFEX Organic Market

*Note: Only standard shell scheme booths are available in these zones

2. Stand Request

2.1 According to the Conditions of Participation, we order the following space at a nett price of:

- USD 430/m² Raw Space (Min. 18m²)
 USD 510/m² Standard Shell Scheme Booth (Min. 9m²)

Space in total m²: _____
(space in total must be divisible by 3)

*Raw Space Only" nominated stand contractor is required to pay a non-refundable admin fee of THB 180 per sqm

3. Co-exhibitor/Principal/Agent

If you have co-exhibitor/principal/agent joining you at the exhibition, please kindly send in **Form 1.20**

PLEASE NOTE:

Payment terms & schedule:

100% of total participation fee due upon date of receipt according to the invoice.

Cancellation terms & schedule:

Date of Cancellation	Cancellation Fee
On or before 31 January 2020	25% of total participation fee
1 February - 3 April 2020	75% of total participation fee. Remaining 25% due if cancelled stand space cannot be resold
On or after 4 April 2020	100% of total participation fee

Data Protection Note:

We would like to keep in touch with you about our business events as well as related services that might be of interest to you. Therefore, we kindly request your consent for allowing us to communicate directly with you via telephone, email, SMS and/or digital media.

You can refer to the details of our complete Koelnmesse Personal Data Protection Policy online at www.koelnmesse.com.sg/koelnmesse-personal-data-privacy-policy

I hereby permit Koelnmesse Pte Ltd to use the details entered on this form for sending information and advertising of industry events staged by Koelnmesse Pte Ltd.

Please, note that at any point in time you can withdraw your consent for future use simply by contacting privacypolicycontroller@koelnmesse.com.sg

Place, date, legally binding signature and company stamp of the main exhibitor

IMPORTANT NOTES:

- Exhibition is open only to professionals, invited guests and trade visitors on trade days, 26 - 29 May 2020.
- Exhibition will be opened to public on Saturday, 30 May 2020 only.
- Badges are non-transferable. Anyone caught misusing another person's badge will be reported to the Organizer.
- The Organizer reserves the right to refuse admission or to remove any person from the event without having to specify a reason.
- Exhibitors are prohibited from selling their products during trade days (26-29 May 2020).
Retail is allowed ONLY on public day on 30 May 2020.
Violation of this rule may result in being banned from participation in the following year.
- All special booth decorations for raw space exhibitor must obtain approval from the organizer prior to the show. Any booths that fail to comply to the stipulated technical and safety requirements will be rejected. The Organizer reserves the rights to request for an amended plan from the exhibitor.
- Exhibitors may not remove any component/furniture at the booth during all exhibition days.
- Exhibitors may not exhibit pirated/counterfeit products, or exhibit/sell products which do not meet specifications mentioned in registration documents.
- No transferring of your registered booth to any third party without prior approval from the organizers.
- Reselling of booths is strictly prohibited.
- During show days, mascot is only allowed to move within the rented booth area.
- Exhibitors are only allowed to portable headsets with sound volume not exceeding 70 decibels.
- Speakers or amplifiers are not allowed.
- Inappropriate behaviour towards organizing staff will not be tolerated.

ENTITLEMENTS

	9 - 12 sqm	15 sqm	18 - 21 sqm	24 - 27 sqm	30 - 36 sqm
Needle punch carpet	As per stand space				
System wall, 2.4mH, white colour, PVC covering	On all closed sides				
Fascia board, with English company name and booth number	On all open sides				
Lockable cabinet	1	1	2	3	4
Floating shelves	3	3	6	9	12
Round table	1	1	2	3	4
Standard chair	2	3	4	6	8
Wastepaper basket	1	1	2	3	4
Spotlight, 100W	3	5	6	9	12
Socket outlet, 5 Amp, 220V	1	1	2	3	4

*Note:

If exhibitors do not want any item(s) stated in the Standard Shell Scheme booth package, the cost of the packages will not change and there will be no replacement with another item(s). Additional stand furniture and electrical items can be rented by completing the respective forms in the Exhibitor Service Manual and returning the completed forms by the stipulated deadlines.

Exhibitors applying for shell scheme designs are not permitted to have any structural changes to their booths. For any booth enhancements, exhibitors are to obtain approval from Organizers. Organizers reserve the right to tear down any unauthorized structures on-site and penalties of up to USD1,000 will be imposed. Maximum height permitted for shell scheme designs are at 2.5mH.

The stand designs provided herewith are illustrative purposes and may be subject to change at the Organizer's discretion.

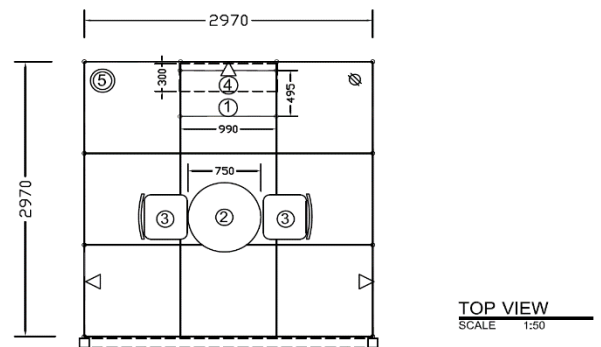
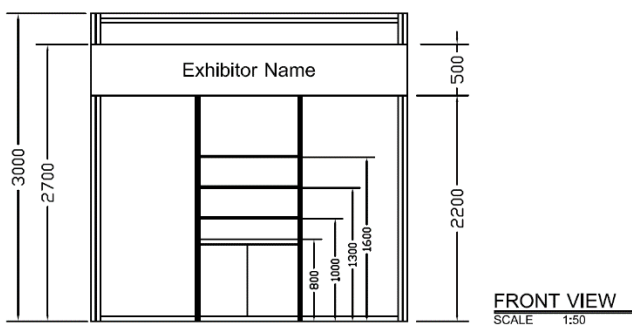

Koelnmesse Pte Ltd
152 Beach Road
#25-05 Gateway East
Singapore 189721
Tel: +65 6500 6700
Fax: +65 6294 8403
l.how@koelnmesse.com.sg
www.worldoffoodasia.com



26 - 30 May 2020

Application for
**CO-EXHIBITOR /
PRINCIPAL /
DISTRIBUTOR**

Deadline:
30 March 2020

1.20

1. Alternative INVOICE address -

If different from Main Exhibitor

If invoice should be changed to address other than that of the Main Exhibitor, please enter below:

Company Name:

Address:

City, Postal Code:

Country:

Website:

Contact person:

Mr Ms

Position at the company:

Phone:

Fax:

Email:

Please note:

The registered company will be obliged to settle the invoice if the recipient of the invoice fails to effect payment.

2. Alternative CORRESPONDENCE address -

If different from Main Exhibitor

If correspondence should be sent to address other than that of the Main Exhibitor, please enter below:

Company Name:

Address:

City, Postal Code:

Country:

Website:

Contact person:

Mr Ms

Position at the company:

Phone:

Fax:

Email:

Data Protection Note:

We would like to keep in touch with you about our business events as well as related services that might be of interest to you. Therefore, we kindly request your consent for allowing us to communicate directly with you via telephone, email, SMS and/or digital media.

You can refer to the details of our complete Koelnmesse Personal Data Protection Policy online at www.koelnmesse.com.sg/koelnmesse-personal-data-privacy-policy

I hereby permit Koelnmesse Pte Ltd to use the details entered on this form for sending information and advertising of industry events staged by Koelnmesse Pte Ltd.

Please, note that at any point in time you can withdraw your consent for future use simply by contacting privacypolicycontroller@koelnmesse.com.sg

Place, date, legally binding signature and company stamp of the main exhibitor

Koelnmesse Pte Ltd
152 Beach Road
#25-05 Gateway East
Singapore 189721
Tel: +65 6500 6700
Fax: +65 6294 8403
l.how@koelnmesse.com.sg
www.worldoffoodasia.com



26 - 30 May 2020

Application for
**CO-EXHIBITOR /
PRINCIPAL /
DISTRIBUTOR**

Deadline:
30 March 2020

1.20

We hereby register companies represented by us on our stand according to the Conditions of Participation.

1. Co-exhibitor

1.1 Address

Company Name:

Address:

City, Postal Code:

Country:

Website:

Contact person for the exhibition is:

Mr Ms

Position at the company:

Phone:

Fax:

Email:

1.2 The co-exhibitor is a/an:

- Association/Institution/Government
- Importer
- Manufacturer
- Service Provider
- Trading Company
- Wholesaler/Distributor
- Others

1.3 The represented brand(s) is/are as follow:

If you have more than one application for co-exhibitor/principal/distributor, please submit one form each per company.

Please note:

The application for a co-exhibitor is **FREE-OF-CHARGE**, including a basic entry in our marketing materials, wherever relevant, according to the Special Conditions of Participation.

The co-exhibitor is not permitted to relocate, exchange, share or in any other way make the stand space allocated to him completely or partially accessible to third parties, without the prior consent of the Organizer.

The acceptance of this application for co-exhibitor is subjected to the sole discretion of the Organizer.

Data Protection Note:

We would like to keep in touch with you about our business events as well as related services that might be of interest to you. Therefore, we kindly request your consent for allowing us to communicate directly with you via telephone, email, SMS and/or digital media.

You can refer to the details of our complete Koelnmesse Personal Data Protection Policy online at www.koelnmesse.com.sg/koelnmesse-personal-data-privacy-policy

I hereby permit Koelnmesse Pte Ltd to use the details entered on this form for sending information and advertising of industry events staged by Koelnmesse Pte Ltd.

Please, note that at any point in time you can withdraw your consent for future use simply by contacting privacypolicycontroller@koelnmesse.com.sg

Place, date, legally binding signature and company stamp of the main exhibitor

GENERAL CONDITIONS OF PARTICIPATION FOR TRADE FAIRS OUTSIDE GERMANY



I. Application

1. By signing and returning the registration form, these General Conditions of Participation shall - together with the Special Conditions of Participation - be acknowledged as legally binding. The information and data being provided by the exhibitor will be electronically saved by the organizer but always observing the regulations stipulated under the applicable Data Protection Laws and such information will be transmitted or disclosed to third parties only to fulfil contractual duties.
2. The regulations stipulated in the Special Conditions of Participation shall prevail over the regulations stipulated in these General Conditions of Participation should there be a conflict between the regulations stipulated in the Special Conditions of Participation and the regulations stipulated in these General Conditions of Participation. The house rules, the technical specifications and the regulations stipulated in the Special Conditions of Participation constitute also a part of the contract.
3. The application shall constitute a legally binding offer of the exhibitor to conclude a contract from the date the organizer receives the application, irrespective of acceptance; the application cannot be appended with conditions or reservations.

II. Acceptance / Transfer of Stand Space / Contractual Obligation

1. The organizer shall accept the application in accordance with the Conditions of Participation, which apply to all participants (acceptance).
2. The acceptance is subject to the organizer's discretion. If the number of application forms complying with the requirement profile and received by the organizer prior to the expiration of the registration period exceeds the number of available exhibition space, the organizer shall have the right to make a discretionary decision regarding the admission of applicants to the exhibition.
3. The exhibitor may be disqualified from admission to the exhibition, if the exhibitor failed in the past to fulfil his financial obligations vis-a-vis the organizer at any time, or if he failed to fulfil such financial obligations within the prescribed period of time.
4. The legally binding contract shall be concluded upon written notification of acceptance. Should the content of the acceptance differ from that of the application (registration), the contract shall be concluded under the terms of the acceptance - even if the acceptance differs from the application - unless the applicant objects in writing within 2 weeks after receipt of the acceptance. The same shall apply, if it is necessary to postpone the event or to transfer the venue of the event, provided that the change can be regarded to be reasonable; in this case, the corresponding notification of change from the organizer shall supersede the admission.
5. The acceptance only applies to the respective event, the company or corporation applying, its products and services. Products, which do not conform to the list of permitted goods, must not be exhibited at the trade fair.
6. The organizer allocates stand space in accordance with the exhibits being registered to belong to a certain topic or theme within the exhibition.
7. There is no legal entitlement for the allocation of stand space in a certain hall or in a certain hall area. If deemed necessary by the organizer, the organizer is entitled to subsequently allocate the stand space other than stated in the acceptance, to change the size and dimensions of the stand space, to relocate or close entrances or exits from and to the stand and to undertake structural changes in the exhibition halls without legal claims against the organizer. In the event of a reduction in stand space size, the exhibitor will be credited with the prorated difference arising from the correspondingly lower space cost. The exhibitor will be notified without undue delay, if the stand space becomes unavailable due to reasons, which are beyond the organizer's control. In this case, the exhibitor

will be entitled to a reimbursement of the participation fee. Any further claims for damages, exceeding the aforementioned reimbursement, shall be expressly excluded.

8. Any complaints by the exhibitor must be submitted in writing without undue delay but at the latest while the event is in progress; the organizer cannot consider complaints at a later date.
9. Furthermore, the organizer shall have the right to rescind the contract for a substantial cause. Such a substantial cause shall be constituted, in particular, if an admissible application for opening insolvency proceedings against the exhibitor's assets has been made or such an application has been dismissed due to lack of funds. The exhibitor must inform the organizer of such circumstances without undue delay.
10. The organizer is entitled to rescind the contract, if the event utilization falls below 50% of the rental stand space. In this case the organizer is not liable for any damages or losses but has to refund already paid fees or downpayments.
11. After the binding registration and the consequent acceptance, release from the contractual relationship is not possible without the organizer's consent.
12. The organizer may agree to the request for release from the contract only in exceptional cases, e.g. if the stand space in question can be rented to another exhibitor. In this case, the organizer is entitled to demand liquidated damages in the amount of 25% of the participation fee without providing any proof. The exhibitor shall have the right to prove that a damage or loss has not been incurred or that the quantum of damage or loss incurred is considerably less. In addition to the liquidated damages, the exhibitor is liable for catalogue fees and other costs and expenses, which in particular, have been incurred as a result of a claim by a third party. The occupancy of stand space by an already accepted and allotted participant by means of a stand exchange does not constitute a mitigating form of stand area rental.
13. Should the exhibitor fail to assume the stand space allotted to him at the beginning of the construction period, the organizer will demand the exhibitor to assume the stand space by setting a reasonable timeframe.
14. Should the timeframe set in accordance with II 13 fruitless expire, the organizer shall have the right to rescind the contract and to assert a claim for damages due to non-performance.
15. The following cases will fall solely within the exhibitor's scope of risk:
 - a) the products, which have been stipulated for the presentation, cannot be introduced at the venue of the event due to legal requirements prevailing there or due to other reasons, or
 - b) such products do not arrive in time, do not arrive undamaged or do not arrive at the venue of the event at all - e.g. as a result of any loss, delay in transport or customs, etc. - or
 - c) the journey of the exhibitor's employees or the exhibitor's stand or installation personnel is delayed or becomes impossible. The exhibitor will in all these cases remain under the obligation to pay all the contractual charges and fees agreed upon.
16. After the exhibition has ended the exhibitor is obliged to leave and return the allotted stand space in a condition that equals the condition when the exhibitor took over the stand space. The timeframe in which the exhibitor has to leave shall be determined by the organizer in the Special Terms of Participation. Should the exhibitor fail to comply with this obligation to vacate in time, the organizer is entitled to remove the exhibitor's belongings from the exhibition place on the exhibitor's expense. Furthermore the organizer shall have the right to sell the exhibitor's belongings and to set off claims against him.

GENERAL CONDITIONS OF PARTICIPATION FOR TRADE FAIRS OUTSIDE GERMANY



III. Construction and Arrangement of Stands

1. All stand constructions and stand designs must comply with statutory safety regulations, and comply with the specified requirements stipulated in the Special Conditions of Participation.
2. All stand construction service providers must have a special permit from the organizer in order to construct the trade fair stands in the exhibition halls. Any additional technical services that may be required, particularly the installation of electricity, water and safety devices, the recruitment of local auxiliary personnel, etc., may be ordered exclusively through the organizer by means of special order forms and against a separate charge, whereas the charges shall be in accordance with the usual charges being market price at the place of venue.
3. For the duration of the event the stands must display the exhibits and be staffed by personnel as stated in the acceptance.
4. The organizer is entitled to demand the removal of exhibits from the stand, which could constitute a considerable disruption to the operation of the event or put the safety of exhibitors and visitors at risk due to their odor, noise, other emissions or appearance. Furthermore, the exhibitor will be responsible for ensuring compliance with all statutory provisions of the host country. In case of non-compliance, the organizer shall also have the right to demand the removal of exhibited articles or the forbearance of a certain activity. Should the exhibitor fail to comply with this demand without undue delay, the organizer is entitled to have the exhibits in question removed at the exhibitor's expense and risk and to close the exhibitor's stand, without any claims for loss or damages against the organizer.
5. The exhibitor is obliged to co-ordinate the construction and design measures for his stand with the organizer in advance. The organizer shall notify the exhibitor about any requested amendments or alterations as early as possible after becoming aware thereof. Furthermore, the exhibitor is obliged to inquire about the relevant statutory regulations, laws etc. or building regulations on his own initiative. Should the exhibitor violate those regulations, the organizer is entitled to vacate or alter the stand on the exhibitor's expense. The organizer does not assume liability for any information provided by him.

IV. Participation Fee and Other Costs / Terms of Payment

1. The amount of the participation fee, the down payment as well as the flat-rate cost of energy will be calculated according to the rates specified in the Special Conditions for Participation. The Invoicing amount will be calculated on the basis of the total stand floor space as allocated and will not exclude any projecting or overhanging parts, pillars, installation connections and other permanent internal fittings.
2. After the exhibitor's admission, the exhibitor will receive an invoice for the participation fee and other costs and possibly a registration fee invoice. The invoice less the downpayment must be paid not later than 10 weeks before the commencement date of the event. The aforesaid invoice amount is to be paid in full without any deductions. Invoices being issued less than 10 weeks prior to the commencement date are due immediately.
3. The organizer is entitled to request a downpayment whereas the due day of such downpayment is stipulated in the Special Conditions of Participation or the downpayment invoice. The rates contractually agreed upon (in the acceptance) are net fixed rates plus legally applicable taxes.
4. The organizer shall have the right to increase the rates by the amount of the corresponding cost increment in the event of any increase in its own prime cost, particularly as a result of higher production, purchasing and labor costs as well as higher fees, taxes and other fiscal charges imposed at the venue of the event. Should the increment exceed 10% of the rates being published by the Organizer in the application forms the Organizer grants the exhibitor the right to terminate the

contract within 10 working days from the date of the receipt of such an increment notice.

5. The payment of all invoices on or before the due date shall prerequisite for the occupation of the stand space.
6. Failure to conduct payment in time will result in interest charges amounting to 6% per annum. Should the damages incurred by the organizer exceed this interest amount, he shall be entitled to these additional damages.
7. Should settlement of the invoice not be effected within the deadline (due date), the organizer is entitled to terminate the contract.
8. As a security for all claims the organizer might have against the exhibitor, the organizer has a pledge on all movable objects belonging to the exhibitor on the stand area.
9. Any services that the organizer has provided will be invoiced either in EUR, in USD or in another currency to be determined by the organizer at the organizer's discretion. The exhibitor is obliged to pay the amount and currency stipulated on the invoice ("billing currency"). Should the organizer, as a courtesy, accept settlement of the invoice in a currency other than the billing currency, such payment must be calculated based on the conversion on the official buying rate of the billing currency on the date of payment. Any exchange rate losses in relation to the billing currency after the invoice becomes due for payment are at the exhibitor's expense.
10. Any complaints relating to the invoice must be made in writing, without undue delay, at the latest 2 weeks after receipt; complaints submitted at a later date cannot be considered.
11. Any projecting or overhanging parts, pillars, installation connections and other permanent internal fittings in the stand space do not entitle the respective exhibitor to any reduction in the participation or other costs.
12. The organizer shall also be entitled to the payment of the full amount, should the exhibitor fail to fulfil any of his contractual obligations. This does not affect further claims for damages. Should the organizer fail to fully or partially fulfil his contractual obligation, the exhibitor is entitled to a proportional reimbursement of any payments already made by the exhibitor. Exceeding claims are excluded in accordance with section VII.
13. In the event of counter claims being made against those claims arising from the contract, the exhibitor may only set off or assert his right of retention in as far as these claims are undisputed or have been awarded by an enforceable judgement.
14. Should an invoice upon request of the exhibitor be sent to a third party, this does not constitute any waiver of claims or obligations of the exhibitor. The latter remains obliged to pay until such time as the account receivable has been settled in full.
15. All payments being due to the organizer must be made in full without deductions, whereas bank charges, currency exchange fees etc. have to be borne by the exhibitor or debtor.

V. Co-exhibitors, Additional, Group and Joint Stands

1. Stand spaces shall be rented out only as a whole unit and only to one contracting party. The exhibitor is not permitted to relocate, exchange, share, or in any other way make the stand space allocated to him completely or partially accessible to third parties, without the prior consent of the organizer.
2. Use of the stand area by another company with its own products and own staff (co-exhibitor) requires a special application for admission and the consequent approval by the organizer. This also applies to companies for which one of the requirements mentioned (own products or own staff) is not fulfilled (additionally represented company). Companies, which are members of a corporate group as well as subsidiaries, are considered to be co-exhibitors. The organizer reserves the right

GENERAL CONDITIONS OF PARTICIPATION FOR TRADE FAIRS OUTSIDE GERMANY



to demand an additional participation charge and other costs for the admission of co-exhibitors / additionally represented companies. Such charges and costs will be invoiced to the exhibitor.

3. Co-exhibitors and additionally represented companies are accepted only under the conditions stipulated in section II of these General Conditions of Participation; these Co-exhibitors and additionally represented companies are equally subject to the Conditions of Participation as they apply to exhibitors.
4. Should an exhibitor accommodate a co-exhibitor or an additionally represented company without the express permission of the organizer, this shall entitle the organizer to immediate termination of the entire contract and to have the stand space vacated at the exhibitor's risk and expense.
5. After the acceptance has been received, the contractual relationship remains exclusively between the organizer and the exhibitor, who is liable for his and the co-exhibitor's and the additionally represented company's non-performance, breach of contract etc.
6. Should several exhibitors wish to participate at the event together on one stand, the General and Special Conditions of Participation are binding for each exhibitor. In addition, they are obliged to name a contact person in their application, jointly appointed as an authorized representative. Moreover the conditions stated in section IV apply analogously. In the event of permitted joint use of the stand space, all exhibitors are liable to the organizers for payment of the participation and other costs and the fulfilment of other obligations - regardless on which legal grounds - as co-debtors.

VI. Domestic Authority

1. The organizer has the right to establish rules of the house for every event. These rules come into force after their publication at the place of the event. The rules of the house become part of the contract. There is no obligation to hand out these rules of the house to each exhibitor and the exhibitors have to inform themselves about the content of the rules of the house.
2. The organizer shall exercise domestic authority throughout the exhibition area. The organizer is entitled to have exhibits removed from stands if their display contravenes statutory laws, is offensive or do not comply with the list of permitted goods.
3. The promotion of political and ideological contents is prohibited. In the event of serious offences against these Conditions of Participation, the organizer is entitled to close the stand or have it vacated.

VII. Warranty / Liability / Insurance

1. The organizer does not assume any obligation to exercise proper care of exhibits, stand fittings and objects, which are the property of the stand personnel. Any liability for damages and losses is expressly excluded, if it is possible to underwrite the risks. This does not affect the liability incurred by wilful acts or grossly negligent misconduct. This exclusion of liability is not affected by security measures of the organizer.
2. Within the scope of liability, the statutory regulations concerning the burden of proof shall continue to apply; they will not be affected by this clause except in cases concerning liquidated damages.
3. It is recommended to conclude an exhibition insurance policy, which can be obtained via the Exhibitor Service Manual. In addition the exhibitor may order special security measures by applying so with the corresponding form in the Exhibitor Service Manual.
4. The exhibitor is liable to the organizer for any damage inflicted on the organizer, provided that such damage is attributable to the exhibitor's culpable (wilful action or negligence) action or the culpable action of the exhibitor's personnel, the exhibitor's employees or any third party which the exhibitor has appointed or any other third parties, whose services the exhibitor is using for the purpose of fulfilling his obligations.

5. Instead of proving the quantum of an incurred damage, the organizer shall be entitled to demand liquidated damages in the amount of 25% of the participation fee (including rent and additional services) without providing any proof. However, in this case the exhibitor shall have the right to prove that a damage or loss has not been incurred or that the quantum of the damage or loss incurred is less than the liquidated damage. The organizer may choose to claim damages exceeding the amount of 25% of the participation fee if the organizer can prove such higher damage.
6. The exhibitor is obliged to strictly comply with the Technical Guidelines, which will be handed over to the exhibitor by the organizer, as well as with the information from the organizer's circular letters with regard to questions on the preparation and implementation of the event. The exhibitor is furthermore obliged to inform himself about legal requirements and necessary permits and to obtain the same.
7. The organizer may request from the exhibitor to obtain an insurance to cover certain risks, which have been specifically addressed to the exhibitor.
8. In the event of any claims regarding fatal injuries, bodily or health injuries, the organizer shall be liable for damages caused intentionally or by gross negligence in accordance with statutory obligations. Other contractual and/or legal damage claims of any type, including damage claims for consequential damages, shall be excluded, unless the damage was caused by the intentional or grossly negligent action of the organizer.
9. The foregoing limitations of liability shall apply, to the full extent, to the executive organs, employees, legal representatives, persons employed in performing an obligation and vicarious agents, whose services are used by the organizer for the performance of the contract. However, all claims shall be restricted to the payment of typical, foreseeable damages. Furthermore, the organizer shall be liable for every culpable infringement of an essential contractual obligation. Essential contractual obligations shall include only those contractual obligations, which are indispensable to the execution of the contract. This applies to all claims, which could arise as a result of, and in connection with, this contract. If the organizer is compelled to temporarily vacate or permanently close the exhibition area or parts thereof, to postpone, shorten or extend the event as the result of a force majeure, or for other reasons beyond his control, the exhibitor is not entitled to any claims, in particular, not to claims for damages or losses against the organizer.
10. The responsibility of the event organizer is limited to fault in all cases without prejudice to any limitations of liability under these Conditions of Participation. If a contract provides for the procurement of certain items, the organizer does not assume the risk of procurement, unless expressly agreed otherwise in individual cases.
11. The warranty period for deliveries of new items is 1 year if there is no shorter statutory warranty period applicable. For second hand articles, any liability based on warranty is excluded. There is no warranty or liability for normal wear and tear, force majeure, faulty or negligent handling, excessive demands or failure to comply with statutory provisions or operating instructions.
12. The exhibitor shall be liable and bear the risk for all damages incurred during transportation to and from the exhibition venue including all damages incurred during transportation within the exhibition building.

VIII. Period of Limitation

1. Any claims of the exhibitor, which may be asserted against the organizer and which may arise from the contractual relationship, as well as all other claims relating thereto, shall become time-barred after one year, unless a shorter statutory limitation period applies or the liability of the organizer results from an intentional action. The longer statutory limitation period for tortuous claims, fraudulent intent and culpable

GENERAL CONDITIONS OF PARTICIPATION FOR TRADE FAIRS OUTSIDE GERMANY



impossibility of performance shall remain unaffected. The limitation period shall commence at the close of the month, in which the closing date of the event falls.

IX. Reservations / Final Provisions

1. The exhibitor is solely responsible for compliance with all the laws, guidelines, and other regulations being applicable at the place of venue of the event, even if the contents of the organizer's conditions for participation deviate from such regulations. The exhibitor must inquire about the relevant regulations prevailing at the venue of the event promptly and comprehensively, and thereby obtain the required information. The organizer will not assume any liability for damages and other losses, which might result from any non-compliance with this obligation.
2. The organizer shall have the right to postpone, shorten, extend or cancel the event, as well as to terminate the event temporarily or definitely, as well as individually or collectively, if such an action is required due to unforeseen events such as force majeure, natural disasters, wars, disturbances, strikes, breakdown or obstruction of traffic and communication. In the event of any postponement, shortening, extension or termination, the exhibitor shall not be entitled to the payment of any resulting damages, which the exhibitor may suffer. The exhibitor shall have the right to rescind the contract, if he loses interest in participating because of such an action and if the exhibitor consequently waives the reservation for the stand space allotted to him. Upon full knowledge of the change, the rescission of the contract must be declared in writing and without undue delay.
3. In case of the cancellation of an event, the organizer shall not be liable for damages and/or other losses, which might be incurred for the exhibitor. Upon request of the organizer, the exhibitor will be obligated to defray a reasonable share of the expenses resulting from the preparation of the event. The amount of the share to be paid by each exhibitor shall be stipulated by the organizer after consultation with the business organizations concerned, whereas the maximum shall be 5% of the total costs. By signing the application form the exhibitor acknowledges the organizer's Conditions of Participation (the General and Special Sections) together with all other regulations relating to the contractual relationship, as legally binding.
4. Should these provisions be or become partially legally invalid or void, this shall not effect the validity of the remaining provisions or the contract. In this event, the parties bind each other to replace the invalid provision with a valid provision that comes to the commercial purpose of the invalid provision as close as possible. The same applies to loopholes.
5. All agreements, approvals and alterations to the contract must be made in writing. The same shall also apply to any amendment or waiver of this written-form clause itself.

X. Place of Fulfilment / Place of Jurisdiction

Provided nothing else has been specified in the Special Conditions of Participation.

1. The contract is subject to Singapore law and to the exclusive jurisdiction of the courts in Singapore. However, the organizer shall be entitled, at his sole option, to initiate the legal proceedings at the place, where the trade fair is held or where the exhibitor is located.

SPECIAL CONDITIONS OF PARTICIPATION



26 May - 30 May 2020

1. The Fair, The Organizers, The Venue, The Dates

The Trade Fair Thaifex - World of Food Asia 2020 is being organized by

Koelnmesse Pte Ltd
152 Beach Road #25-05 Gateway East
Singapore 189721

- hereinafter referred to as the organizer.

The exhibition is being held from Tuesday 26 May to Saturday 30 May 2020, at IMPACT Exhibition & Convention Center, Bangkok, Thailand.

The exhibition is open to exhibitors on Tuesday 26 May to Friday 29 May, from 08:00am to 7:00pm, and on Saturday, 30 May from 08:00am to 12:00am. International exhibitors can leave at 06:00pm on Saturday, 30 May 2020.

The exhibition is open to visitors on Tuesday 26 May to Friday 29 May, from 10:00am to 06:00pm, and on Saturday, 30 May from 10:00am to 08:00pm.

The period for setting up and the period for dismantling shall be determined by the organizer as set out in the Exhibitor Service Manual. The period for dismantling sets the timeframe in which the exhibitor has to leave (cf. II. (16) in the General Conditions of Participation).

2. Eligibility to Take Part

Exhibitors should be manufacturers of goods that are included in the nomenclature of the exhibition ("List of Goods" as stated in the application forms) and if they are produced by the exhibitor at his own manufacturing plant or are offered as parts or accessories thereof. Admission is also open to exhibitors displaying items or offering services which, in accordance with the List of Goods, are in keeping with the overall theme of the event, and which the exhibitor has had manufactured or offered under his own name.

In addition, importers and dealers may participate, if their application for Thaifex - World of Food Asia is approved by the manufacturer(s) of the respective products and brands and if they are not to be exhibited by the original manufacturer.

The agreement of the manufacturer(s) must be documented upon request. In case of failure of this pre-condition, the organizer has the right to withdraw the acceptance of the importer and/or dealer.

The organizer will decide upon the acceptance of firms or products.

3. Participation Costs, Payment Terms and Cancellation Terms

Your participation will entail the following costs:

Stand Costs - Exhibition

- In the halls per square metre excluding stand construction, excluding provision of stand partition walls (minimum size 18m²): 430 USD

The construction of the stand shall be obligated to the exhibitor.

- In the halls per square metre with standard shell scheme construction (minimum size 9m²): 510 USD

The rented space in total must be divisible by three m² (9, 18, 27, etc.). The stand costs include the rent for the exhibition space for the entire duration of the event including the setting up and dismantling periods, a specific number of exhibitor and work badges, the use of all general technical and service facilities in the fair halls like lighting, ventilation, air conditioning, use of electricity on the stand, general surveillance of the halls and cleaning of the aisles; consulting on organisational matters by Koelnmesse Pte Ltd employees, catalogue entry according to Item 7.

The stand costs do not include the installation and use of compressed air, the installation of water connections and the use of water on the stand.

For two-storey exhibition stands, the actual allotted area in the upper storey following the technical inspection is calculated at 50% of the raw space price per m² of floor area. For multiple island booths who wish to utilize the connecting aisle space by carpet or construction (arch or banner), it is calculated at 50% of the raw space price: USD 430 per sqm of floor area.

If the Application for Main Exhibitor 1.10 is received by the organizer 100% of total participation fee incurred is due upon date of receipt. An invoice of the said amount will be issued and sent to you. This invoice is to be paid in full before commencement of the event according to the terms of payment as indicated on the invoice.

The aforementioned payments may be made by cheque or wire transfer according to the terms of payment as indicated on the said invoices. All bank and administrative charges as well as foreign exchange differences are to be borne by exhibitors.

If an exhibitor fails to pay according to the abovementioned terms and payment schedule, the organizer reserves the right to release without notice to the exhibitor the stand space reserved for exhibitor.

If an exhibitor cancels its participation ON OR BEFORE JAN 31, 2020, the exhibitor shall remain liable to the Organizer for liquidated damages in the amount of 25% of the total participation fee.

If an exhibitor cancels its participation Feb 01 - April 03, 2020 (both dates inclusive), the exhibitor shall remain liable to the Organizer for liquidated damages in the amount of 75% of the total participation fee. If the stand space in question cannot be rented to another participant before the commencement of the event, the exhibitor shall be liable to the Organizer for liquidated damages in the remaining amount of 25% of the total participation fee.

If exhibitor cancels its participation ON OR AFTER April 04, 2020 or fails for any reason whatsoever to utilize the stand space allotted to him, the exhibitor shall remain liable to the Organizer for liquidated damages in the amount of 100% of the total participation fee (including any balance due at the time of cancellation).

Any notice of cancellation to be given hereunder is required to be in writing to Koelnmesse Pte Ltd and shall not be effective until such cancellation notice is received by Koelnmesse Pte Ltd. No cancellation shall relieve the exhibitor of his obligation to pay any sums due to Koelnmesse Pte Ltd prior to the effective date of such cancellation.

If a written request to change (downsize) the assigned exhibit space(s) is received by Koelnmesse Pte Ltd, a downsize and / or re-allocation of the stand space is subject to the absolute discretion of the organizer. The exhibitor is obligated to pay Koelnmesse Pte Ltd liquidated damages of total participation fee of change (downsize) in the event that the original space cannot be rented to another participant before the commencement of the event.

The stand costs for the shell scheme construction include: (cf. also Application for Main Exhibitor 1.10/2 "Shell Scheme Specification")

General setting up and dismantling of the stand, incl. all additional costs consisting of:

- General hall cleaning of the aisle
- Laying carpet over the entire booth area
- Booth partition walls (rear and side walls) as per stand space
- Fascia board with Company Name
- Booth furniture per booth: as specified in Form 1.10/2 "Shell Scheme Specification"

The stand costs do not include the installation and use of compressed air and water connections on the stand.

SPECIAL CONDITIONS OF PARTICIPATION



26 May - 30 May 2020

Co-exhibitors

As far as accommodation of other companies or firms will be permitted on the stand (cf. figure V. (2) in the General Conditions of Participation, whereas co-exhibitors and additionally represented companies will be treated as the same), their application will be free-of-charge. This includes the basic catalogue-entry according to item 7.

All and any costs caused by the co-exhibitor or services additionally ordered shall be payable separately by the main exhibitor.

4. Fitting and Arrangement of the Stands

- (a) Please take into account that where necessary hall pillars and other permanent construction features are contained in the rented stand spaces, the participation fee is calculated on the basis of the exact measurements of the stand space allocated.
- (b) Stand construction will only then commence if the exhibitor orders standard stand construction.
- (c) Any planned structure exceeding 4 metre must be approved in advance by Koelnmesse Pte Ltd and the hall proprietor in writing. The stand must be constructed to comply with the dimension of the space allocated. Plans for non-standard structures or designs for stands with meeting rooms or where technical calculations are required, as well as plans for technical fittings should be submitted to Koelnmesse Pte Ltd and the hall proprietor in duplicate for perusal not later than 6 weeks prior to the beginning of the event.

In the event of these plans having to be scrutinised by the proprietor of the halls, Koelnmesse Pte Ltd shall assume responsibility for forwarding them as commissioned by and for the account of the exhibitor and shall notify the exhibitor of the outcome. Koelnmesse Pte Ltd will not release the exhibitions space in question for construction work until the results of the inspection have been received.

Any other fitting and arrangement of the stand is left to the exhibitor but should be appropriate for the event in question. The exhibitions company's name must be clearly visible on each stand.

Each Shell Scheme exhibitor will receive a stand design with number of the booth according to the stand confirmation. The stand design has to be clearly visible during all the exhibition time.

5. Exhibitor Badges and Badges for Stand Construction Personnel

As an exhibitor you will receive:

Size of booth	Quantity of badges
Up to 12 sqm	4 nos.
13 - 24 sqm	8 nos.
25 - 30 sqm	12 nos.
31 - 39 sqm	16 nos.
More than 39 sqm	20 nos.

The badges will be valid from the first day of the setting up period until the last day of the dismantling period.

Used exhibitor badges, i.e. those with the names of stand personnel printed on them, may be exchanged once for new badges free of charge in case the stand personnel will be replaced during the exhibition. The new badges can be obtained at the Exhibitor Service Office.

You will also receive free badges to enable the company personnel to enter the trade fair complex for the purpose of setting up and dismantling the stand (worker badges). These badges are only valid during the setting up period and dismantling period. They do not entitle the holder to enter the complex during the exhibition. You can order these badges with the correct order form in the Exhibitor Service Manual.

Non-company stand designers require a special permit to undertake construction work in the halls.

6. Rules on Selling

In view of the professional nature of the event, the organizer shall have the right to prohibit the direct sale and open-price-labeling of exhibits or samples on the stands, in particular in case of official order or to intervene in all cases where safety and orderly conduct on the exhibition floor is at peril.

Compensation or claims for reimbursement by the exhibitor are ruled out in the case of the afore-mentioned measures.

7. Show Guide

Koelnmesse Pte Ltd issues for its fairs and exhibitions a show guide which includes an alphabetical list of firms and advertisements. This makes the show guide an important and up-to-date source of reference for all interested persons and also provides it added value after the fair.

The reproduction of advertisements is offered separately in the Exhibitor Service Manual and are subject to an extra charge. All entries in the show guide must be submitted to Koelnmesse Pte Ltd or to the company commissioned by Koelnmesse Pte Ltd 8 weeks prior to the first day of the event. The organizer of the fair reserves the right to commission a third company with the production of the catalogue.

Koelnmesse Pte Ltd does not accept any liability for printing errors, incorrect placing, mistakes and other gaps or faults in printing. The advertiser shall be responsible for the subject matter of advertisements and entries and for any omission or mistake resulting from them.

8. Verbal Agreements

Any verbal agreements, individual permissions and exceptions outside the framework of this contract are not valid until confirmed in writing by the organizer.

9. Exhibitor Service Manual

After signing the application form and the formal admission of the exhibitor by the organizer, the exhibitor will receive the Exhibitor Service Manual. In this manual the exhibitor can order the different free-of-charge and charge-able services (such as e.g. additional furniture, additional stand cleaning, extra stand security, etc.) that the organizer offers.

10. Intellectual Property Rights

Koelnmesse Pte Ltd, as a professional Organizer for international exhibition, respects and expects our Exhibitors to respect the lawful rights of the owners of intellectual property rights. For the purpose of protecting the lawful rights of the owners of intellectual property rights and facilitating the handling of intellectual property infringement complaints at the exhibition held by Koelnmesse Pte Ltd, Koelnmesse has set out the intellectual property protection rules to be complied with at the exhibition in the Exhibitor Service Manual according to the relevant Singapore laws and regulations. Please refer to the Exhibitor Service Manual for details.

11. General Conditions of Participation

We would like to draw your attention to the provisions contained in the General Conditions of Participation for Trade Fairs outside Germany. All legal relationships between you and the organizer are subject exclusively to the laws of Singapore. The house rules and the regulations set down in the Special Section of the Conditions of Participation form part of the contract.

12. Personal Data Privacy Policy

Your personal data privacy is important to us and the organizer is highly committed in respecting and managing personal data collected through this application form. Please refer to the organizer's website at <http://www.koelnmesse.com.sg/koelnmesse-personal-data-privacy-policy> for the policy details. By signing this application form, the exhibitor acknowledges and agrees to be bound by this policy in respect of how your personal data will be collected, used and (where required) disclosed by the organizer.